

# TLM 2 MPa (20 bar)

3-WAY INLINE FILTERS

3-WEGELEITUNGSFILTER

FILTRES EN LIGNE 3-JONCTIONS

FILTROS EN LINEA A 3-VIAS

FILTRI IN LINEA A 3-VIE

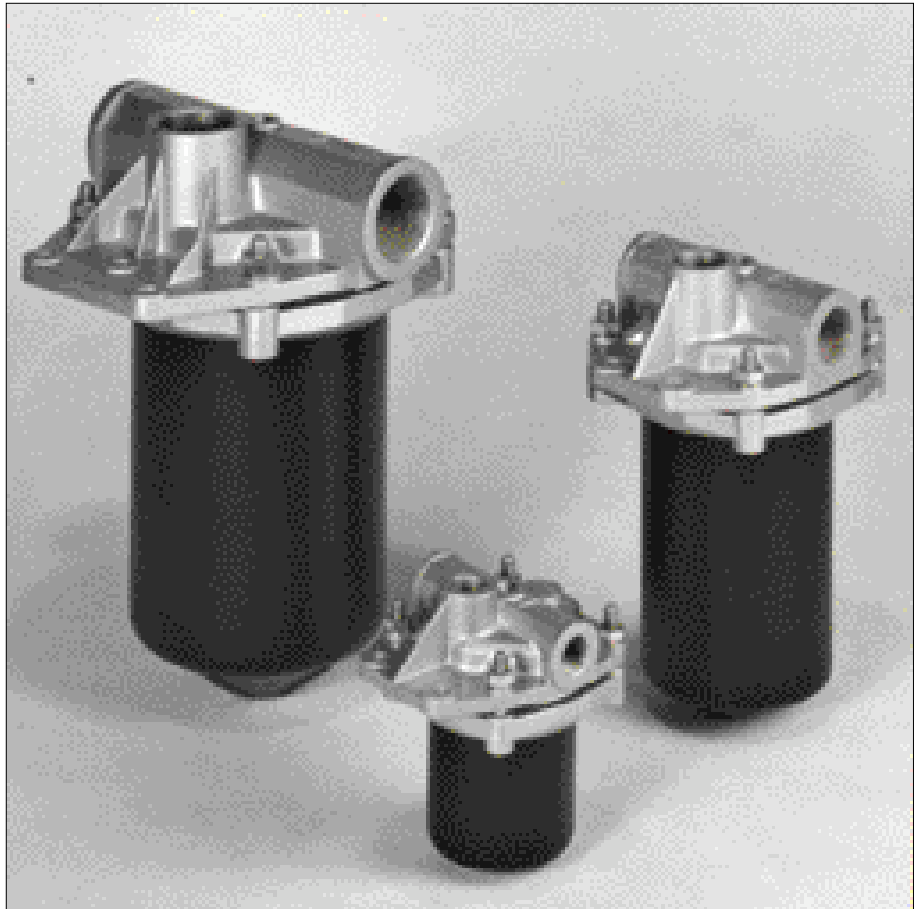

**SOFIMA**

  
**FILTERS**  
**HYDRAULIC**

## GB 3-way inline filters - TLM series -

**DESCRIPTION:** TLM series filters are especially designed to be suitable for stationary and mobil applications. Suction, inline and return assembly with inlet and outlet port in "L" configuration (Sx. or Dx.)

Port sizes: 3/8" ÷ 1 1/2" BSP-NPT - Flow rates: 4 ÷ 600 L/min.

### TECHNICAL DATA

**Max. working pressure:** 2 MPA (20 bar)  
**Max. test pressure:** 4 MPA (40 bar)  
**Burst pressure:** 6 MPA (60 bar)  
**Fatigue test:** 0 ÷ 1 MPa (0 ÷ 10 bar) / 300.000 cycles  
**Head:** aluminium  
**Bowl:** cold formed steel  
**Working temperature:** -25 ÷ +110°C

**FILTER ELEMENTS WITH BY-PASS**  $\Delta p$  1,7 bar (170 kPa)  $\pm$  0,2  
**Inorganic fibres:** 10 $\mu$  - 25 $\mu$  Abs.  
**Paper:** 10 $\mu$  - 25 $\mu$   
**Steel wire mesh:** 60 $\mu$  - 125 $\mu$   
**Special execution on request.**

### FILTER ELEMENTS COLLAPSE PRESSURES

Standard:  $\Delta p$  500 kPa (5 bar) all types

**SEALS** Standard: Buna-N - On request: FKM - Fluoroelastomer

All tests performed according to the following standards: **ISO 2941:** Element collapse resistance test - **ISO 2942:** Production integrity test  
**ISO 2943:** Fluids compatibility - **ISO 3723:** End load test method - **ISO 3724:** Flow fatigue resistance method - **ISO 3968:** Pressure drop versus flow rate - **ISO 16889:** Multipass test. For further information contact our Technical Dept.

## D 3-Wegeleitungsfilter - TLM Serie -

**BESCHREIBUNG:** Die Leitungsfilter der TLM Serie werden auf stationären und mobilen Anlagen eingebaut.

Saug-, Leitungs-, und Rücklaufmontage. Zwei Anschlüsse in „L“ Form : (lks. oder re.)

Anschlüsse: 3/8" ÷ 1 1/2" BSP-NPT Durchflussmengen: 4 ÷ 600 L/min.

### TECHNISCHE DATEN

**Max. Betriebsdruck:** 2 MPA (20 bar)  
**Max. Prüfdruck:** 4 MPA (40 bar)  
**Berstdruck:** 6 MPA (60 bar)  
**Ermüdungstest:** 0 ÷ 1 MPa (0 ÷ 10 bar) / 300.000 Zyklen  
**Kopf:** Aluminium  
**Behälter:** kaltumgeformter Stahl  
**Betriebstemperatur:** -25 ÷ +110°C

**FILTERELEMENTE MIT BYPASS-VENTIL**  $\Delta p$  1,7 bar (170 kPa)  $\pm$  0,2

**Anorganische Fasern :** 10 $\mu$  - 25 $\mu$  Abs.

**Spezial Papier:** 10 $\mu$  - 25 $\mu$

**Metallgewebe:** 60 $\mu$  - 125 $\mu$

**Sonderausführungen auf Wunsch.**

### KOLLAPSDRUCK DES FILTERELEMENTS

Standard:  $\Delta p$  500 kPa (5 bar) jeder Typ

**DICHTUNGEN** Standard: Buna-N - Auf Wunsch: FKM - Fluorelastomer

Alle Prüfungen werden nach folgenden Normen durchgeführt: **ISO 2941:** Kollaps u. Berstdruckprüfung - **ISO 2942:** Feststellung der einwandfreien Fertigungsqualität - **ISO 2943:** Prüfung der Verträglichkeit des Materials mit den Flüssigkeiten - **ISO 3723:** Verfahren zur Prüfung der Endscheibenbelastung - **ISO 3724:** Prüfung zur Bestimmung der Ermüdungseigenschaften - **ISO 3968:** Bestimmung des Durchflusswiderstandes in Abhängigkeit vom Volumenstrom - **ISO 16889:** Multipass Test

## F Filtres en ligne à 3 voies - série TLM -

**DESCRIPTION:** Les filtres de la série TLM sont prévus pour être utilisés sur des installations fixes et mobiles. Montage en aspiration, en ligne et au retour par des raccords avec configuration "L" (Sx. o Dx.)

Raccords: 3/8" ÷ 1 1/2" BSP-NPT - Débits: 4 ÷ 600 L/min.

### INFORMATIONS TECHNIQUES

**Pression max de service:** 2 MPA (20 bar)  
**Pression max. d'essai:** 4 MPA (40 bar)  
**Pression d'éclatement:** 6 MPA (60 bar)  
**Essai de fatigue:** 0 ÷ 1 MPa (0 ÷ 10 bar) / 300.000 cycles  
**Tête:** aluminium  
**Bol:** acier moulé  
**Temperature de travaille:** -25 ÷ +110°C

**ELEMENTS FILTRANTS AVEC BY-PASS**  $\Delta p$  1,7 bar (170 kPa)  $\pm$  0,2

**Fibres inorganiques:** 10 $\mu$  - 25 $\mu$  Abs.

**Papier special:** 10 $\mu$  - 25 $\mu$

**Trellis métal:** 60 $\mu$  - 125 $\mu$

**Production special sur demande.**

### PRESSION D'ECRASUREMENT ELEMENTS FILTRANTS

Standard:  $\Delta p$  500 kPa (5 bar) tous les types

**JOINTS** Standard: Buna-N - Sur demande: FKM - Fluoroélastomère

Tous les tests sont réalisés selon les standards suivant: **ISO 2941:** Test de pression d'écrasement élément filtrant - **ISO 2942:** Conformité aux détails de production - **ISO 2943:** Compatibilité media/fluids - **ISO 3723:** Détermination résistance à la déformation axiale - **ISO 3724:** Détermination résistance selon variation du débit - **ISO 3968:** Détermination des pertes de charge selon le débit - **ISO 16889:** Test Multipass.

## E Filtros en linea a 3 vias (1 entrada - 2 salidas) - serie TLM -

**DESCRIPCIÓN:** Los filtros de la serie TLM se pueden montar sobre instalaciones fijas o móviles. Montaje en aspiración, línea o retorno. Disponen de 1 entrada y 2 salidas (Sx. o Dx.) - Conexiones: 3/8" ÷ 1 1/2" BSP-NPT - Caudales: 4 ÷ 600 L/min.

### CARACTERISTICAS TÉCNICAS

**Presión máx de servicio:** 2 MPA (20 bar)  
**Presión máx de prueba:** 4 MPA (40 bar)  
**Presión de rotura:** 6 MPA (60 bar)  
**Ensayo de fatiga:** 0 ÷ 1 MPa (0 ÷ 10 bar) / 300.000 ciclos  
**Cabezal:** Aluminio  
**Cuerpo:** Acero estampado  
**Temperatura de servicio:** -25 ÷ +110°C

**ELEMENTOS FILTRANTES CON BY-PASS**  $\Delta p$  1,7 bar (170 kPa)  $\pm$  0,2

**Fibra inorgánica:** 10 $\mu$  - 25 $\mu$  Abs.

**Papel especial:** 10 $\mu$  - 25 $\mu$

**Tela metálica:** 60 $\mu$  - 125 $\mu$

**Ejecución especial bajo pedido.**

### PRESION DE APLASTAMIENTO DEL CARTUCHO FILTRANTE

Estándar:  $\Delta p$  500 kPa (5 bar) todos los modelos

**JUNTAS** Estándar: Buna-N - Bajo demanda: FKM - Fluoroelastomero

Todos los ensayos se realizan según las normas siguientes: **ISO 2941:** Verificación de la presión de aplastamiento del cartucho - **ISO 2942:** Verificación de conformidad a la fabricación - **ISO 2943:** Compatibilidad de los materiales con los fluidos - **ISO 3723:** Prueba de resistencia a la deformación axial - **ISO 3724:** Prueba de resistencia a la fatiga - **ISO 3968:** Pérdidas de carga según el caudal - **ISO 16889:** Prueba multipass

## I Filtri in linea a 3 vie - serie TLM -

**DESCRIZIONE:** I filtri in linea serie TLM sono progettati per essere utilizzati su impianti fissi e mobili. Montaggio in aspirazione, in linea e al ritorno con attacchi configurati a "L" (Sx. o Dx.). Attacchi: 3/8" ÷ 1 1/2" BSP-NPT - Portate: 4 ÷ 600 L/min.

### CARATTERISTICHE TECNICHE

**Pressione max. di esercizio:** 2 MPA (20 bar)  
**Pressione max. di collaudo:** 4 MPA (40 bar)  
**Pressione di scoppio:** 6 MPA (60 bar)  
**Test di fatica:** 0 ÷ 1 MPa (0 ÷ 10 bar) / 300.000 cicli  
**Testata:** alluminio  
**Corpo:** acciaio stampato  
**Temperatura di lavoro:** -25 ÷ +110°C

**ELEMENTI FILTRANTI CON BY-PAS**  $\Delta p$  1,7 bar (170 kPa)  $\pm$  0,2

**Fibre inorganiche:** 10 $\mu$  - 25 $\mu$  Abs.

**Carta speciale:** 10 $\mu$  - 25 $\mu$

**Tele metalliche:** 60 $\mu$  - 125 $\mu$

**Esecuzioni speciali su richiesta.**

### PRESSIONE COLLASSO CARTUCCE FILTRANTI

Standard:  $\Delta p$  500 kPa (5 bar) tutti i tipi

**GUARNIZIONI** Standard: Buna-N - A richiesta: FKM - Fluoroelastomero

Tutti i test sono stati eseguiti secondo le seguenti norme: **ISO 2941:** Test verifica pressione collasso cartuccia - **ISO 2942:** Test verifica di conformità di fabbricazione - **ISO 2943:** Test verifica compatibilità materiali con fluidi - **ISO 3723:** Test per resistenza alla deformazione assiale - **ISO 3724:** Test determinazione resistenza alla fatica - **ISO 3968:** Test perdite di carico in funzione della portata - **ISO 16889:** Prova Multipass

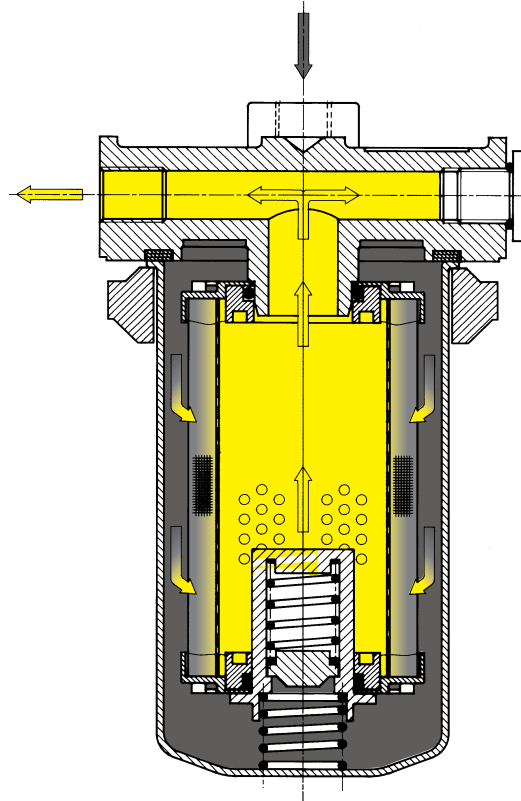

**CLOGGING INDICATORS  
VERSCHMUTZUNGSANZEIGEN**

**INDICATEURS DE COLMATAGE  
INDICATORI DI INTASAMENTO**

<p><b>5B</b></p>	<p><b>6B</b></p>
<p><b>7B</b></p>	<p><b>T0</b></p>
<p><b>31</b></p>	<p><b>80&amp;81</b></p>
<p><b>10</b></p>	<p><b>90&amp;92</b></p>
<p><b>70</b> On request only. See page 15 - Nur auf Wunsch. Sehen Sie Seite 15 Seulement sur demande. Voir la page 15 - Solo su richiesta. Vedi pagina 15</p>	

Series Serie Série Serie	Setting Tarierung Réglage Taratura	Type Typ Type Tipo
<b>Return line - Rücklaufleitung - Retour - Ritorno</b>		
5B	1,3 bar (130 kPa)	Visual differential - Optischer Differenzdruckanzeiger Différentiel visuel - Differenziale visivo
6B	1,3 bar (130 kPa)	Electrical differential - IP65 - Connection plug DIN43650 Elektrisch Diff. - IP65 - Steck-Verbindung nach DIN43650 Différentiel électrique - IP65 - Raccordement DIN43650 Differenziale elettrico - IP65 - Connessione DIN43650
7B	1,3 bar (130 kPa)	Indicator 6B with LED (24V) Verschmutzungsanzeige 6B mit LED (24V) Indicateur 6B avec LED (24V) Indicatore 6B con LED (24V)
T0	1,3 bar (130 kPa)	Electrical with thermostat 30°C IP65 - Connection plug DIN43650 Elektrisch mit Thermostat 30°C IP65 - Steck-Verbindung nach DIN43650 Électrique avec thermostat 30°C IP65 - Raccordement DIN43650 Elettrico con termostato 30°C IP65 - Connessione DIN43650
70	1,3 bar (130 kPa)	On request only - Nur auf Wunsch Seulement sur demande - Solo su richiesta
31	0-12 bar (0-1,2 MPa)	Pressure gauge - Manometer Manomètre - Manometro
80	1,5 bar (150 kPa)	Pressure switch N.O. Druckschalter N.O. Pressostat N.O. Pressostato N.A. (Max 220V / 1A)
81	1,5 bar (150 kPa)	Pressure switch N.C. Druckschalter N.C. Pressostat N.F. Pressostato N.C. (Max 220V / 1A)
<b>Suction line - Saugleitung - Aspiration - Aspirazione</b>		
10	-	Vacuum gauge - Vakuummeter Vacuomètre - Vuotometro
90	0,2 bar (20 kPa)	Vacuum switch N.O. Vakuumschalter N.O. Interrupteur à vide N.O. Vuotostato N.A. (Max 220V / 4A)
92	0,2 bar (20 kPa)	Vacuum switch N.C. Vakuumschalter N.C. Interrupteur à vide N.F. Vuotostato N.C. (Max 220V / 1A)

TLM 019-055

TLM 115-150

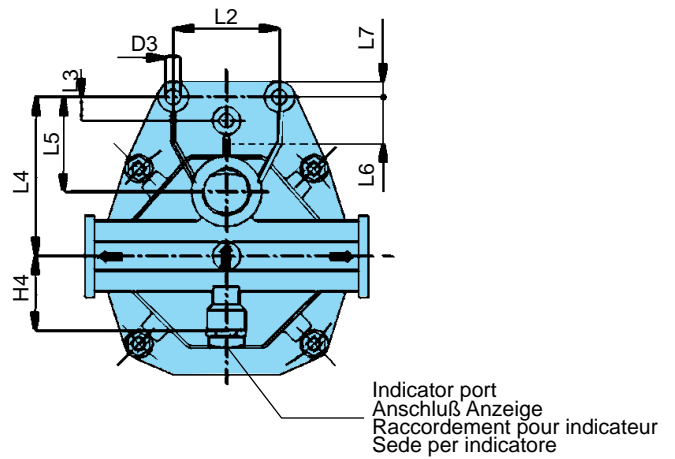
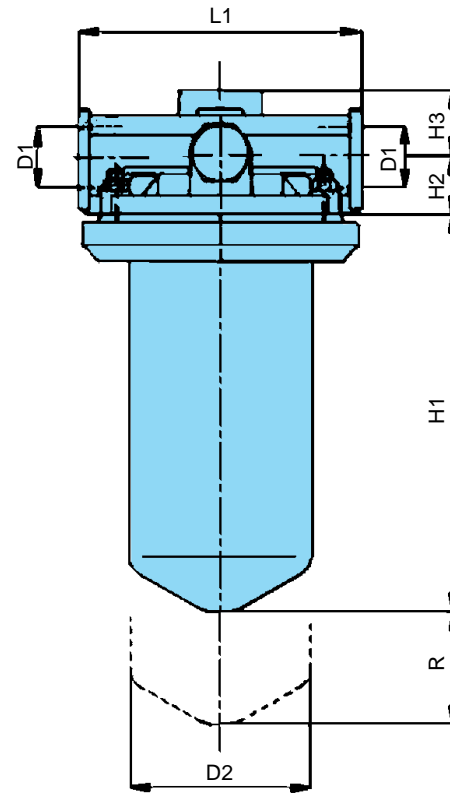
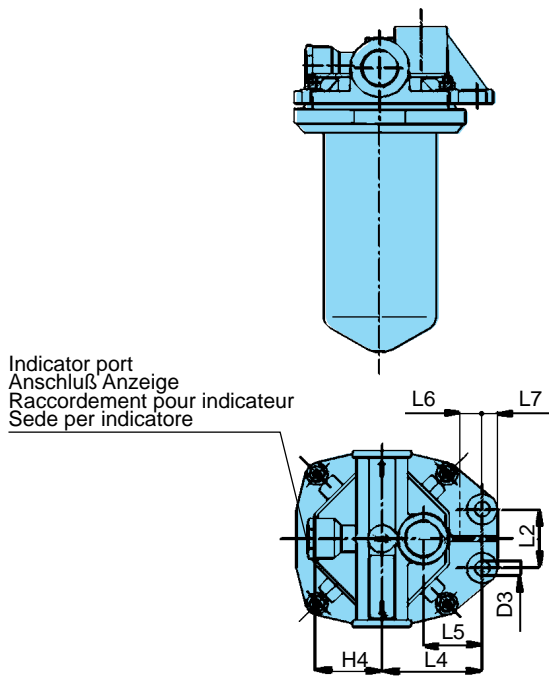

DIMENSIONS AND WEIGHTS  
MASSE UND GEWICHTE

(mm) - (Kg)

DIMENSIONS ET POIDS  
DIMENSIONI E PESI

Type Typ Type Tipo	D1	H1	H2	H3	L1	D2	H4	L2	D3	L3	L4	L5	L6	L7	R	Kg
TLM 019	3/8" - M18 x1,5 - 1/2"	114	19	27	114	81	44	50	8.5	-	70	42	15	10	20	1.3
TLM 055	3/4" - 1"	204	30	35	150	114	58		10.5	-	85	50	12	3.2		
TLM 115	1 1/4"	200	38	45	240	156	62	90	13	20	135	80	56	13	25	6.1
TLM 150	1 1/2"		250	6.8												

**HOW TO ORDER THE COMPLETE FILTER  
BESTELLBEZEICHNUNG FÜR KOMPLETTFILTER  
DETERMINATION D'UN FILTRE  
ORDINAZIONE DEL FILTRO COMPLETO**

**HOW TO ORDER REPLACEMENT CARTRIDGES  
BESTELLBEZEICHNUNG FÜR FILTERELEMENTE  
CODIFICAZIONE CARTOUCHE DE RECHANGE  
ORDINAZIONE DELLA CARTUCCIA DI RICAMBIO**

<b>TLM</b>	Type - Typ - Type - Tipo	019	055	115	150	Type - Typ - Type - Tipo	<b>CRE</b>
		015	048	058	100		

Filter media - Filtermaterial Finesse média - Materiale filtrante				Filter media - Filtermaterial Finesse média - Materiale filtrante					
<b>FC = 6µ</b>	Inorganic fibres	Anorganische Fasern	<b>FC</b>	<b>FC</b>	<b>FC</b>	<b>FC</b>	<b>FC = 6µ</b>	Inorganic fibres	Anorganische Fasern
<b>FD = 12µ</b>	Fibre inorganique	Fibre inorganiche	<b>FD</b>	<b>FD</b>	<b>FD</b>	<b>FD</b>	<b>FD = 12µ</b>	Fibre inorganique	Fibre inorganiche
<b>FV = 25µ</b>	β>200		<b>FV</b>	<b>FV</b>	<b>FV</b>	<b>FV</b>	<b>FV = 25µ</b>	β>200	
<b>CD = 10µ</b>	Paper	Papier	<b>CD</b>	<b>CD</b>	<b>CD</b>	<b>CD</b>	<b>CD = 10µ</b>	Paper	Papier
<b>CV = 25µ</b>	Papier	Carta	<b>CV</b>	<b>CV</b>	<b>CV</b>	<b>CV</b>	<b>CV = 25µ</b>	Papier	Carta
<b>MV = 25µ</b>			<b>MV</b>	<b>MV</b>	<b>MV</b>	<b>MV</b>	<b>MV = 25µ</b>		
<b>MS = 60 µ</b>	Steel wire mesh	Metallgewebe	<b>MS</b>	<b>MS</b>	<b>MS</b>	<b>MS</b>	<b>MS = 60 µ</b>	Steel wire mesh	Metallgewebe
<b>MN = 125µ</b>	Treillis metal	Tela metallica	<b>MN</b>	<b>MN</b>	<b>MN</b>	<b>MN</b>	<b>MN = 125µ</b>	Treillis metal	Tela metallica
<b>DC = 250µ</b>			<b>DC</b>	<b>DC</b>	<b>DC</b>	<b>DC</b>	<b>DC = 250µ</b>		

Seals - Dichtungen - Joints - Guarnizioni				Seals - Dichtungen - Joints - Guarnizioni			
<b>1 = NBR - Nitrile - Buna-N</b>			<b>1</b>	<b>1</b>	<b>1</b>	<b>1</b>	<b>1 = NBR - Nitrile - Buna-N</b>
<b>2 = FKM - Fluoroelastomer</b>			<b>2</b>	<b>2</b>	<b>2</b>	<b>2</b>	<b>2 = FKM - Fluoroelastomer</b>

<b>B</b>	<b>Bypass type - Type de by-pass Bypass typ - Tipo di bypass</b>				
	<b>B = With - Mit - Avec - Con 1,7 bar (170 kPa)</b>	<b>B</b>	<b>B</b>	<b>B</b>	<b>B</b>

	<b>Ports - Anschlussart Raccordements - Tipo di Attacchi</b>				
	<b>B = BSP</b>	<b>B</b>	<b>B</b>	<b>B</b>	<b>B</b>
	<b>N = NPT</b>	<b>N</b>	<b>N</b>	<b>N</b>	<b>N</b>
	<b>M = metric (only - nur - seulement - solo M2)</b>	<b>M</b>	-	-	-

	<b>Port size - Anschlüsse Raccordements - Grandezza attacchi</b>				
	<b>2 = 3/8" (M18)</b>	<b>2</b>	-	-	-
	<b>3 = 1/2"</b>	<b>3</b>	-	-	-
	<b>4 = 3/4"</b>	-	<b>4</b>	-	-
	<b>5 = 1"</b>	-	<b>5</b>	-	-
	<b>6 = 1 1/4"</b>	-	-	<b>6</b>	-
	<b>7 = 1 1/2"</b>	-	-	-	<b>7</b>

	<b>Indicators - Verschmutzungsanzeigen Indicateurs - Indicatori</b>				
	<b>03 = Port for diff.ind., plugged-Anschluß für Diff., verschlossen Racc. pour indic. differ. bouché-Sede per ind. differenziale tappata</b>	<b>03</b>	<b>03</b>	<b>03</b>	<b>03</b>
	<b>5B = Visual diff. - Opt. Diff. - Diff. visuel - Diff. visivo 1,3 bar (130 kPa)</b>	<b>5B</b>	<b>5B</b>	<b>5B</b>	<b>5B</b>
	<b>6B = Elec. diff. - Elek. Diff. - Diff. elec - Diff. Elettr. 1,3 bar (130 kPa)</b>	<b>6B</b>	<b>6B</b>	<b>6B</b>	<b>6B</b>
	<b>7B = 6B with LED - 6B mit LED - 6B avec LED - 6B con LED</b>	<b>7B</b>	<b>7B</b>	<b>7B</b>	<b>7B</b>
	<b>T0 = Elec. - Elek. - Elec. - Elettr. 1,3 bar (130 kPa) with thermostat 30°C</b>	<b>T0</b>	<b>T0</b>	<b>T0</b>	<b>T0</b>
	<b>0R = 1/8" Predisposition - Mit Bohrungen - Predisposizione - Predisposizione</b>	<b>0R</b>	<b>0R</b>	<b>0R</b>	<b>0R</b>
	<b>31 = Pressure gauge - Manometer - Manomètre - Manometro</b>	<b>31</b>	<b>31</b>	<b>31</b>	<b>31</b>
	<b>80 = Pressure switch N.O.-Druckschalter N.O.-Pressostat N.O.-Pressostato N.A.</b>	<b>80</b>	<b>80</b>	<b>80</b>	<b>80</b>
	<b>81 = Pressure switch N.C.-Druckschalter N.C.-Pressostat N.F.-Pressostato N.C.</b>	<b>81</b>	<b>81</b>	<b>81</b>	<b>81</b>
	<b>08 = 1/8" Predisposition - Mit Bohrungen - Predisposizione - Predisposizione</b>	<b>08</b>	<b>08</b>	<b>08</b>	<b>08</b>
	<b>10 = Vacuum gauge - Vakuummeter - Vacuomètre - Vuotometro</b>	<b>10</b>	<b>10</b>	<b>10</b>	<b>10</b>
	<b>90 = Vacuum switch O.C. - Vacuumschalter O.K. - Vacuostat C.O. - Vuotostato C.A.</b>	<b>90</b>	<b>90</b>	<b>90</b>	<b>90</b>
	<b>92 = Vacuum switch C.C. - Vacuumschalter G.K. - Vacuostat C.F. - Vuotostato C.C.</b>	<b>92</b>	<b>92</b>	<b>92</b>	<b>92</b>

**N.B. Indicator 70**  
On request only  
Nur auf Wunsch  
Seulement sur demande  
Solo su richiesta

**Return line - Rücklaufleitung - Retour - Ritorno**  
**In-line - Leitung - En ligne - In linea**

**Suction line - Saugleitung**  
**Aspiration - Aspirazione**

<b>XX</b>	<b>Accessories - Zubehör - Accessoires - Accessori</b>				
	<b>XX = No accessory available - Nicht lieferbar Pas d'accessoires prévus - Non previsti</b>	<b>XX</b>	<b>XX</b>	<b>XX</b>	<b>XX</b>

**FLOW RATES**  
**NENNVOLUMENSTROM**

(L/min)  
 $\Delta p$  0,3 ÷ 0,4 bar (30 ÷ 40 kPa)

**DEBITS**  
**PORTATE**

Type Typ Type Tipo	Media	$\Delta p$ ...		
		0,05	0,2	0,4
TLM 019....B2	FD	4	16	26
	FV	6	18	35
	CD	6	21	34
	CV	7	23	40
	MS	8	25	44
	MN	8	27	49
TLM 019.... M2	FD	6	20	45
	FV	6	22	46
	CD	8	28	45
	CV	8	30	53
	MS	10	32	57
	MN	11	34	64
TLM 019.... B3	FD	7	23	46
	FV	9	27	55
	CD	9	28	53
	CV	11	34	62
	MS	13	38	64
	MN	15	42	68

The reference fluid has a kinematic viscosity of 30 cSt and a density of 0,86 kg/dm<sup>3</sup>

Bezugsflüssigkeit mit kinematischer Viskosität von 30 cSt und Dichte von 0,86 kg/dm<sup>3</sup>

Type Typ Type Tipo	Media	$\Delta p$ ...		
		0,05	0,2	0,4
TLM 055....B4	FD	13	48	89
	FV	16	52	95
	CD	16	61	106
	CV	19	68	117
	MS	21	76	132
	MN	23	87	140
TLM 055....B5	FD	21	76	143
	FV	28	93	162
	CD	25	98	167
	CV	34	121	182
	MS	36	129	197
TLM 115	MN	49	148	208
	FD	30	132	250
	FV	38	197	298
	CD	38	170	291
	CV	49	216	334
TLM 150	MS	57	223	379
	MN	68	265	409
	FD	49	230	365
	FV	77	303	410
	CD	68	276	409
	CV	106	352	462
	MS	114	371	511
	MN	182	428	568

Fluid de reference viscosité à 30 cSt densité 0,86 kg/dm<sup>3</sup>

Fluido di riferimento, avente viscosità cinematica di 30 cSt e densità di 0,86 kg/dm<sup>3</sup>

**FILTER AREA**  
**FILTERFLÄCHE**

(cm<sup>2</sup>)

**SURFACE FILTRANTE**  
**SUPERFICIE FILTRANTE**

Type Typ Type Tipo	CD	CV	MS	MN	FD	FV
CRE 015	990	990	460	460	620	620
CRE 048	3390	3390	1600	1600	3010	3010
CRE 058	4360	4360	2550	2550	4140	4140
CRE 100	6520	6520	2955	2955	6190	6190